

Item	Qty	Description
1	2	Base Plate
2	1	33" RR91 Vertical Extrusion
3	1	33" RR91 Vertical Extrusion
4	1	33" RR91 Vertical Extrusion
5	1	33" RR91 Vertical Extrusion
6	5	26" Z45 Horizontal Extrusion
7	16	3" Z45 Horizontal Extrusion

**Steps:**

- 1) Connect lower verticals [2] and [3] to baseplates [1], using bolts.
- 2) Attach upper verticals [4] and [5] to lower verticals [2] and [3].  
See **Extrusion Connector** detail.
- 3) Attach vertical assemblies [2/4] and [3/5], using horizontals [6].
- 4) Attach horizontals [7] to sides of vertical assemblies, as shown.
- 5) Place shelves onto horizontals [6] and [7].

Keep V15 connectors attached to extrusions [2] and [3] when packing.

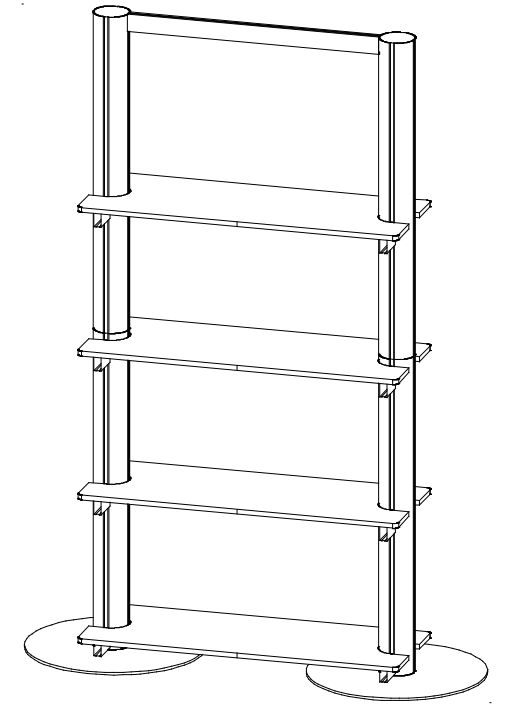

Completed Assembly

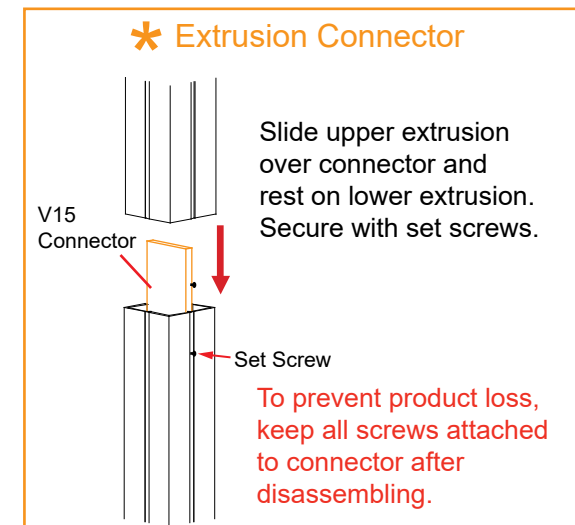
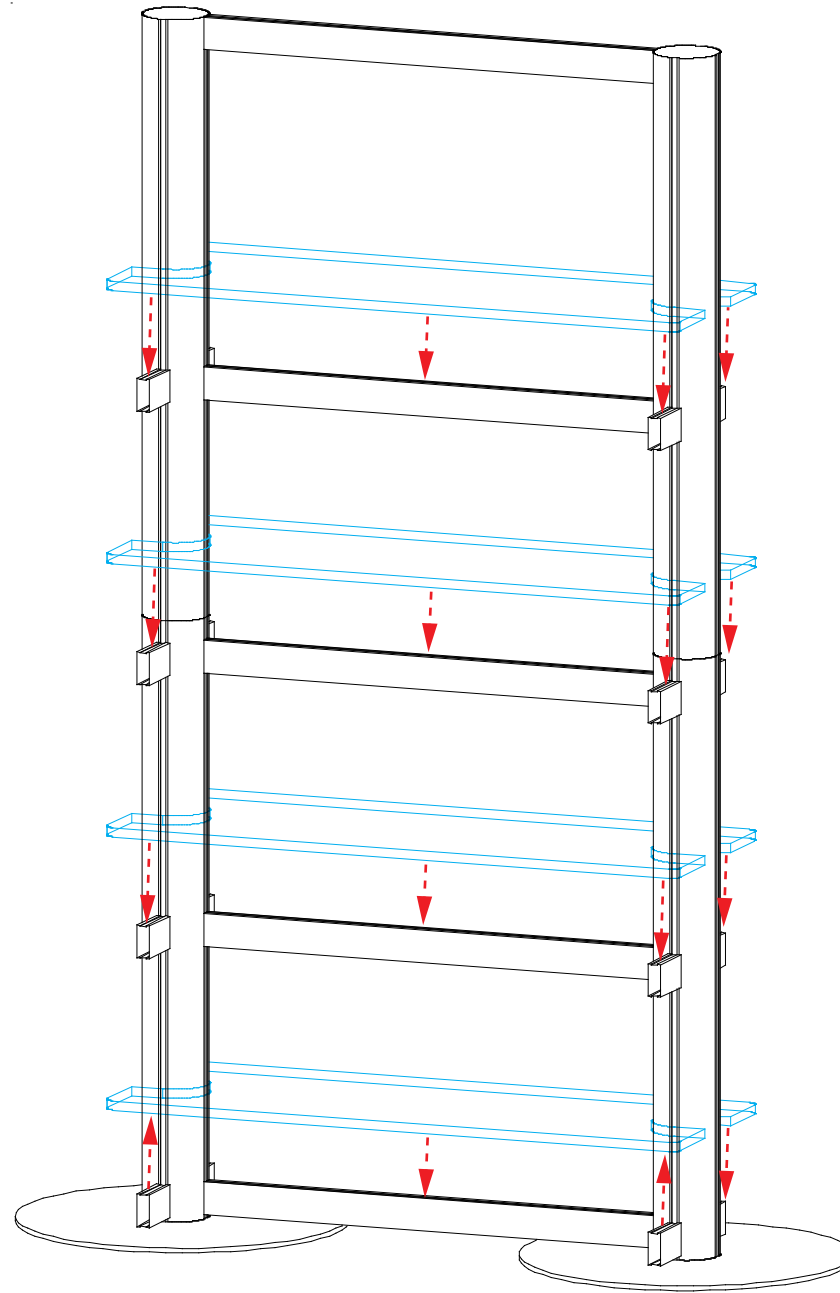
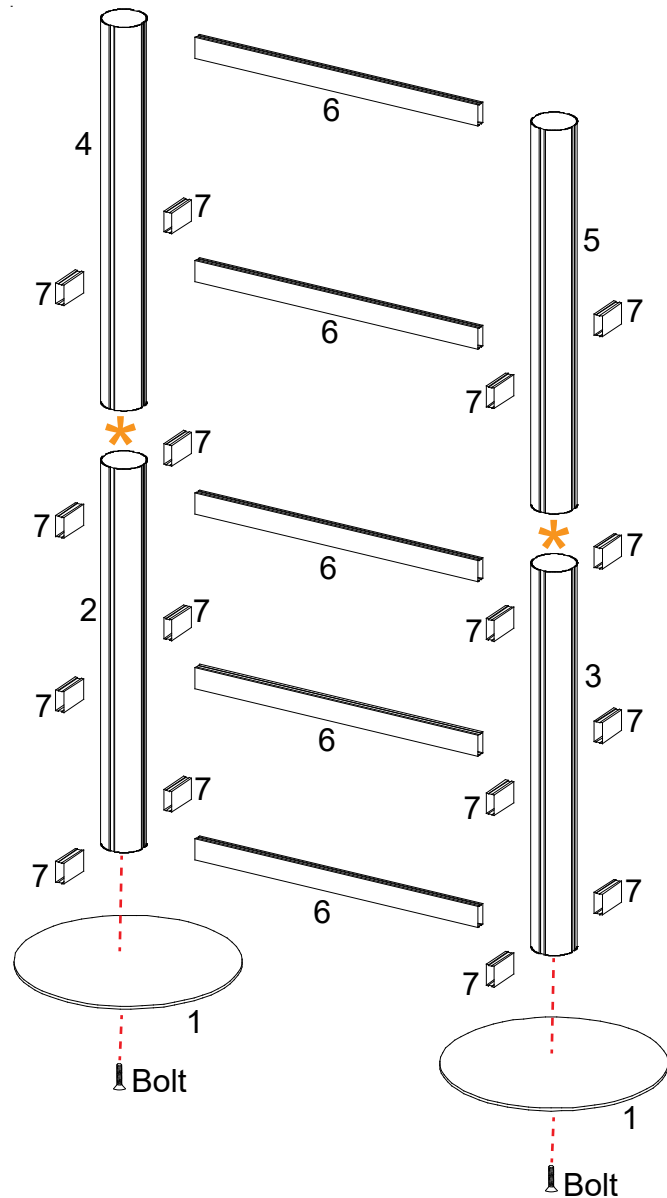

# SETUP INSTRUCTIONS

## General Setup Instructions

- Read entire setup instruction manual prior to unpacking parts and pieces.
- The setup instructions are created specifically for this configuration.
- Setup instructions are laid out sequentially in steps, including exploded views with detailed explanation for assembly.

## Cleaning & Packing

- For Cleaning Metal, Plex, & Laminate Parts: Use a **MILD NON-ABRASIVE** cleanser and soft cloth/paper towel to clean all surfaces.
- Keep exhibit components away from heat and prolonged sun exposure. **Heat and UV exposure will warp and fade components.**
- Retain all provided Packing Materials. All provided packing materials are for ease of repacking & component protection.

## Disassembly

- For loss prevention, tighten all set screws and locks during disassembly.

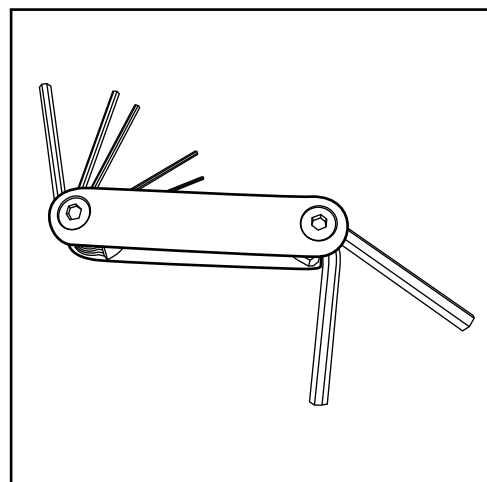

Hex Tool - Essential for Assembly

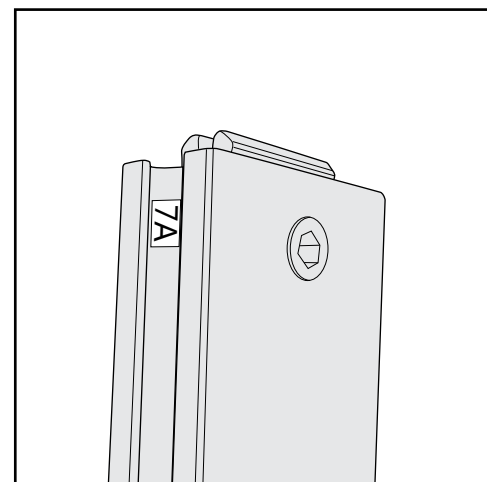

Part Identification - Numbering

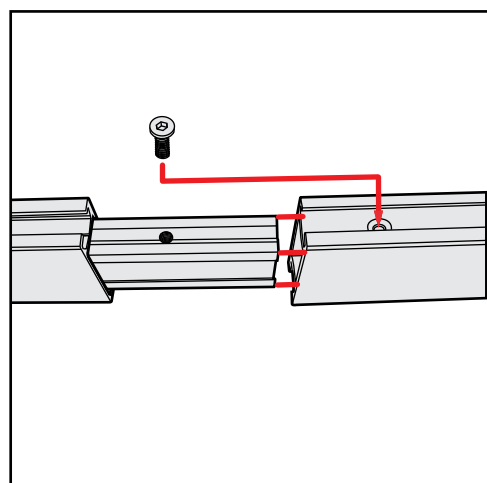

Spline Connection

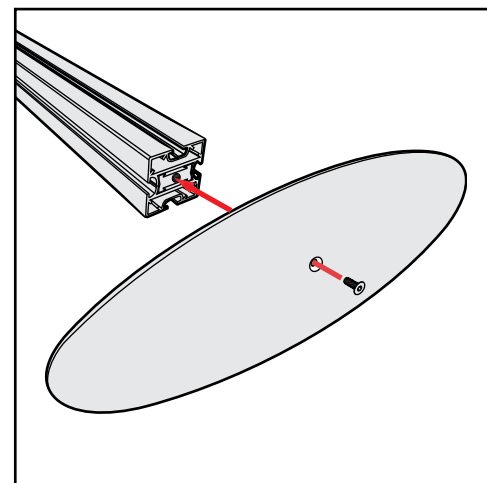

Base Plate & Extrusion Connection

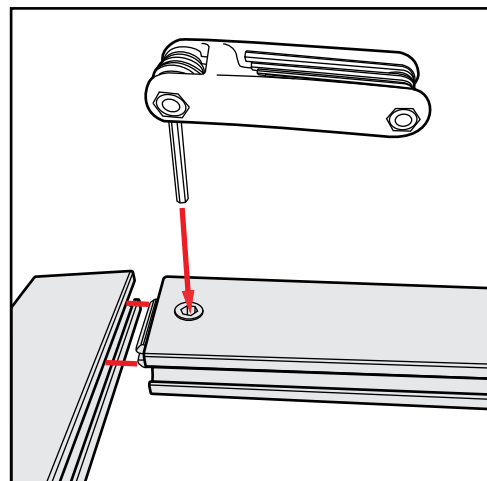

Extrusion & Lock Connection

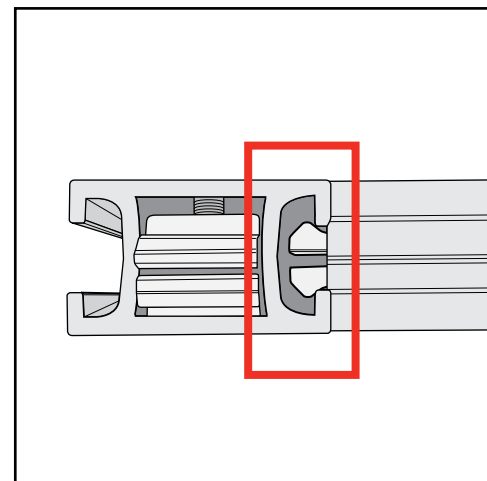

Engaged Lock



**WARNING**

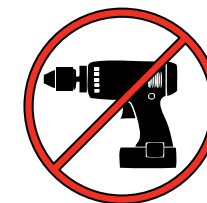

DO NOT USE POWER TOOLS



LADDERS OR LIFTS  
MAY BE REQUIRED



ALL CONNECTIONS MUST  
BE TIGHTLY SECURED

### Top View of Each Level

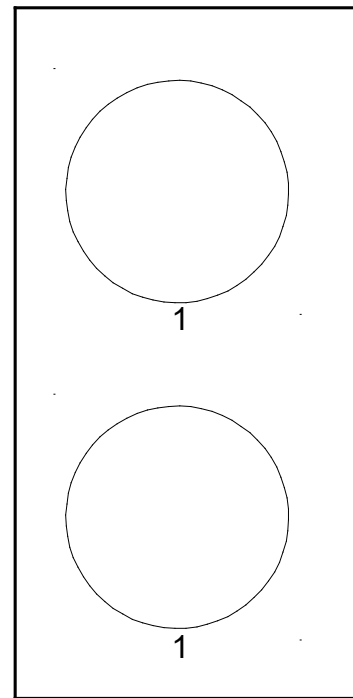

Level 1  
(Bottom level)

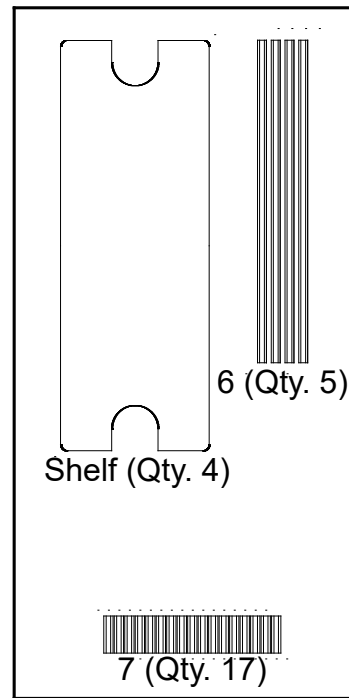

Level 2

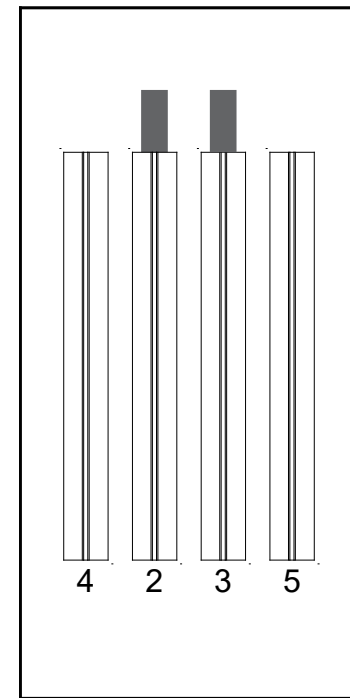

Level 3

